

Bambu Lab P2S

The Icon, Redefined.





2nd-Gen UI on 5-Inch Touchscreen

The P2S features a fully upgraded touchscreen and a powerful processor, running our new intuitive **second-generation UI**. Enjoy smoother interactions, richer graphics, and clearer step-by-step instructions.

PMSM Servo Extruder

The PMSM servo extruder delivers up to **8.5 kg** of maximum extrusion force—**70% more** than its predecessor—dramatically improves high-flowrate extrusion stability. Our proprietary servo architecture samples resistance and position at **20 kHz**, actively detecting filament grinding and clogs in real time.

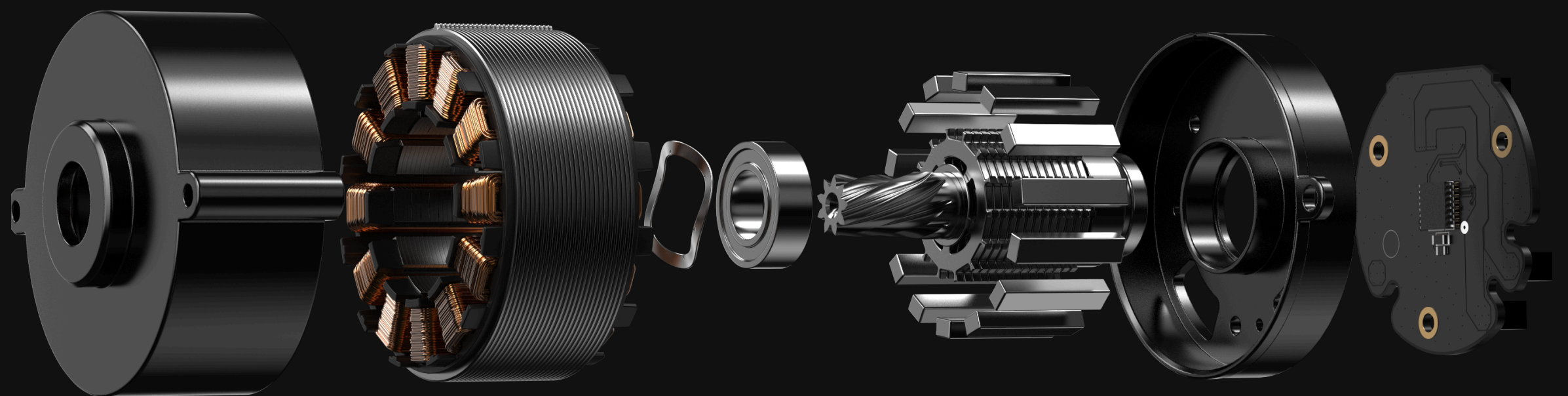

Auto Flow Dynamics Calibration

The P2S uses a high-resolution, high-frequency eddy current sensor to **calibrate flow dynamics**. Intelligent algorithms actively adjust the flow rate based on these readings, provide **precise, consistent extrusion** across every layer and corner.

Adaptive Airflow Cooling

Unlike traditional cooling systems that recirculate hot air, the P2S's Adaptive Airflow System draws in **cool air** directly from **outside the chamber**. This significantly improves **cooling efficiency**, letting you confidently print low-temperature filaments with the **door closed**—without worrying about overhang quality or nozzle clogs.



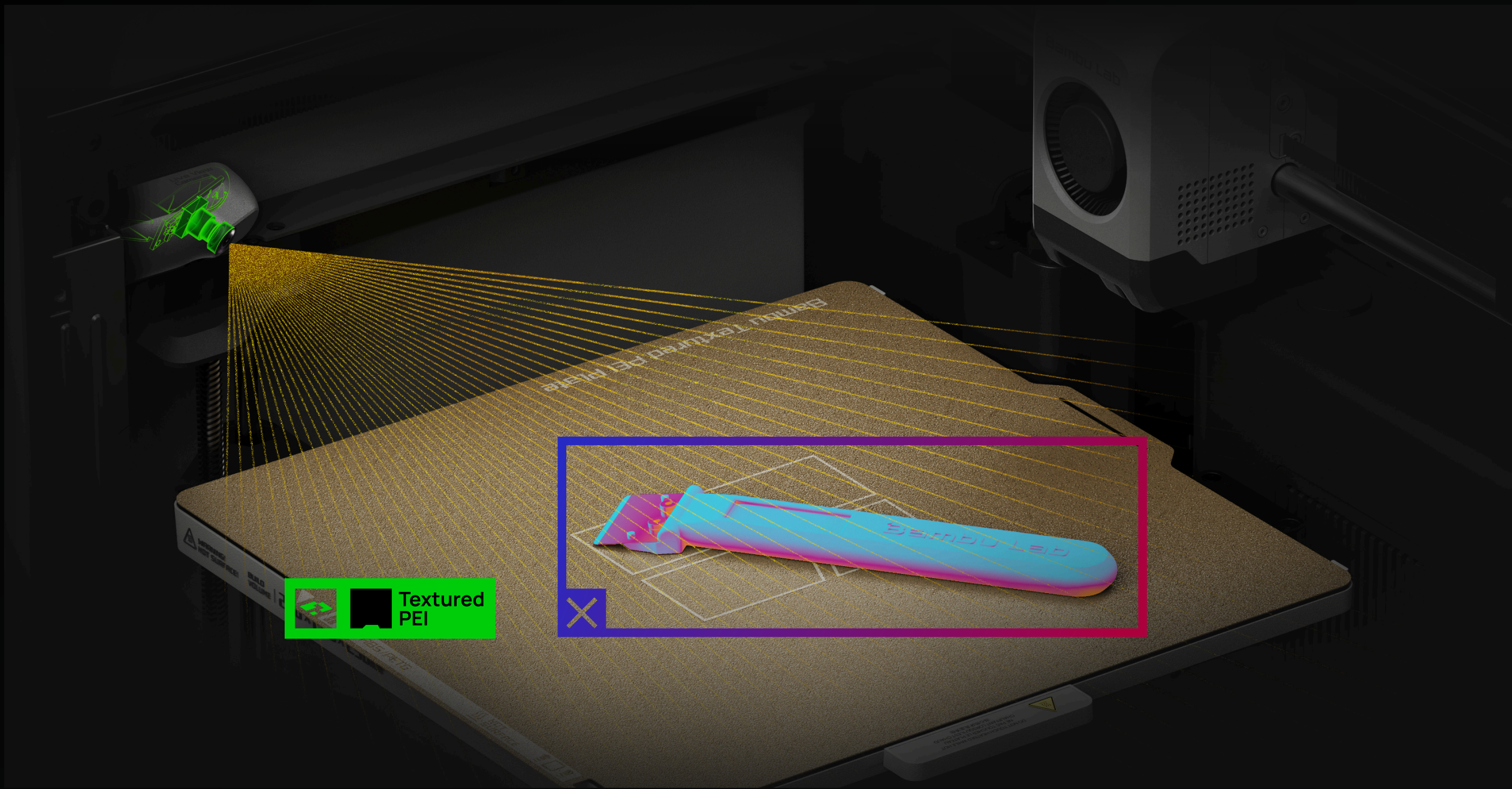

AI Error Detection

The P2S introduces advanced AI computer vision that actively detects common printing issues such as spaghetti, nozzle blobbing. It also checks your print start settings, ensuring a safe and accurate start to every print job.

1080P High-Rate Liveview

Enhanced LED lighting dramatically improves the clarity of your live view video and timelapses. Paired with a high-frame-rate camera, you can comfortably monitor your printer remotely and capture beautifully illuminated timelapses perfect for sharing on social media.



Perfection, Detail by Detail.



Built-in 2-in-1 Buffer (equipped with AMS combo)



Flat Base Plate

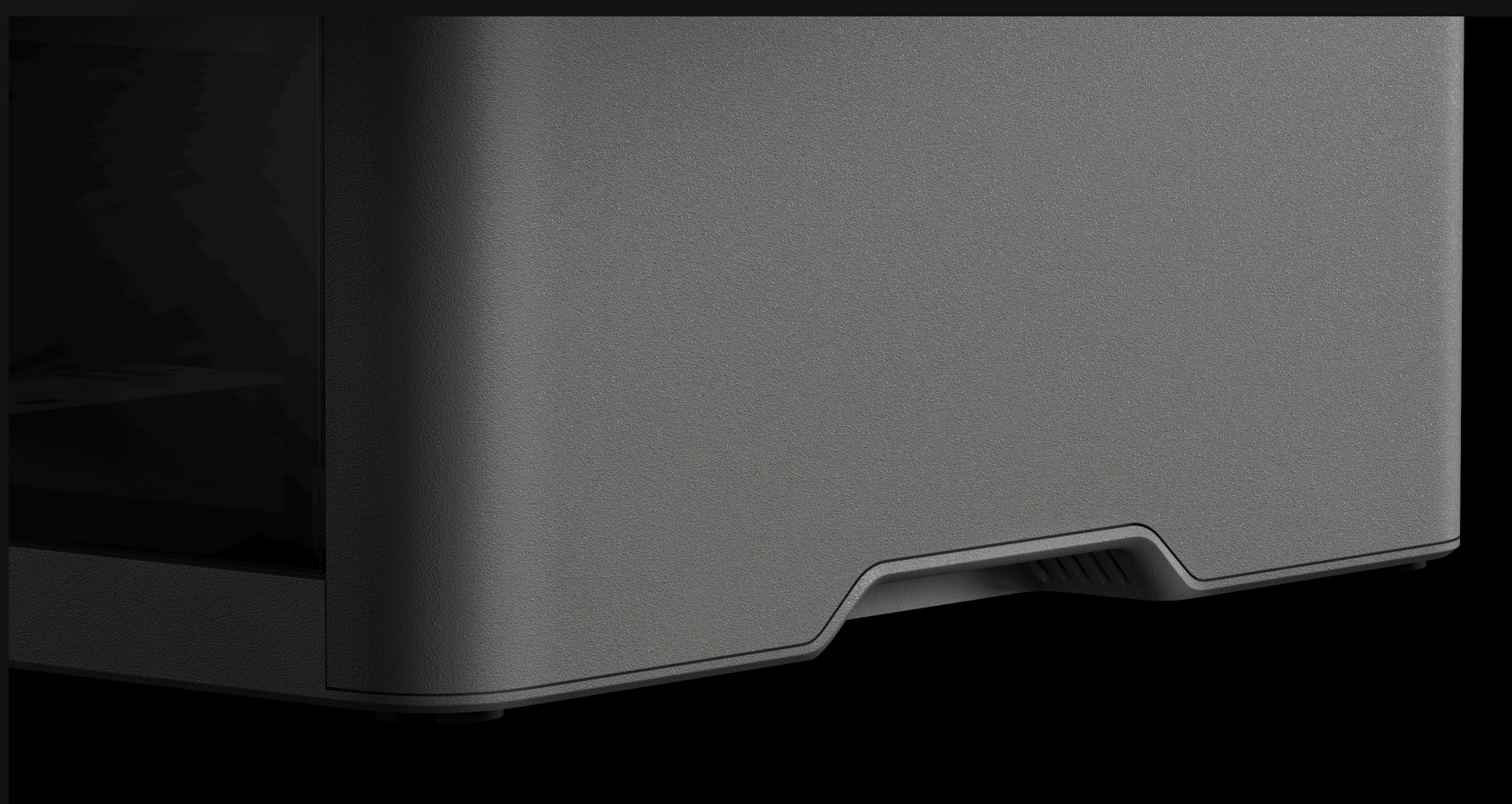

Integrated Lift Handles



Shatter-Safe Front Glass

Item		Specification
Body	Build Volume (W*D*H)	256*256*256 mm ³
	Chassis	Plastic and Steel
	Outer Frame	Plastic and Glass
Physical Dimensions	Physical Dimensions	392*406*478 mm ³
	Net Weight	14.9 kg
Toolhead	Extruder Gear	Hardened Steel
	Nozzle	Hardened Steel
	Max Nozzle Temperature	300 °C
	Supported Nozzle Diameter	0.2 mm, 0.4 mm, 0.6 mm, 0.8 mm
	Extruder Motor	Bambu Lab High-precision Permanent Magnet Synchronous Motor
Heatbed	Supported Build Plate Type	Textured PEI plate, Smooth PEI Plate, Cool Plate SuperTack
	Max Heatbed Temperature	110 °C
Speed	Max Speed of Toolhead	600 mm/s
	Max Acceleration of Toolhead	20,000 mm/s ²
	Max Flow for Hotend	40 mm ³ /s (Test parameters: 250 mm round model with a single outer wall; Bambu Lab ABS; 280 °C printing temperature)
Air Purification	Filter Type	Activated Carbon
	VOC Filtration	Supported
	Particulate Matter Filtration	Supported
Cooling	Part Cooling Fan	Closed Loop Control
	Cooling Fan for Hotend	Closed Loop Control
	Auxiliary Part Cooling Fan	Closed Loop Control
Filament Supported	PLA, PETG, ABS, ASA, TPU, Support for PLA, Support for PLA/PETG, Support for ABS, PET, PA, PC, PVA, PLA-CF, PETG-CF, ABS-GF, ASA-CF, PA6-CF, PA6-GF, PAHT-CF, PPA-CF, PET-CF	
Sensor	Camera	Built-in; 1920*1080; 30 fps HD
	Door Sensor	Supported
	Filament Run Out Sensor	Supported
	Filament Tangle Sensor	Supported
	Power Loss Recovery	Supported
Electrical Requirements	Voltage	100-120 VAC / 200-240 VAC, 50/60 Hz
	Max Power*	1200 W@220 V / 1000 W@110 V
	PLA Steady-State Power	200 W@220 V / 200 W@110 V (PLA printing)
Electronics	Touchscreen	5-inch 854*480 Touchscreen
	Storage	Built-in 8 GB EMMC and USB Port
	Neural Processing Unit	2 TOPS

* To ensure the heatbed quickly reaches the needed temperature (35-110°C), the printer will maintain maximum power for about 3-5 minutes.